



GSA prices effective April 6, 2020
(based on January 6, 2020, commercial price list)
Published June 2021

Multipurpose Seating Caper® Chairs

General Services Administration Federal Supply Service Authorized Federal Supply Schedule Price List

Online access to contract ordering information, terms and conditions, up-to-date pricing, and the option to create an electronic delivery order is available through GSA Advantage!, a menu-driven database system. The Internet address for GSA Advantage! is www.gsaadvantage.gov.

Office Furniture
FSC Group 71, Part 1
Contract Number: GS-03F-036DA
Contract Period: December 21, 2015—December 20, 2025

Herman Miller, Inc.
855 East Main Avenue
Zeeland, Michigan 49464
(616) 654 3000 Phone
(616) 654 8278 Fax
www.HermanMiller.com/government

Business Size: Large

Contract Information

1a. Special Item Numbers (SIN)

SIN 33721

Furniture Systems, Computer Furniture, Filing and Storage, Tables and Accessories, Upholstered Seating and Multi-Purpose Seating, Project Management, Reconfiguration and Relocation Services, Design/Layout and Installation Services

SIN 33721P

Packaged Offices

SIN 337127

Modular Laboratory Furniture Systems

SIN NEW

New Product Introductions

SIN OLM

Order-Level Materials (OLMs)

This SIN is only for products and/or services used in direct support of the purchase of new furniture. It requires approval from the ordering Contract Officer. Please contact your local Herman Miller representative to discuss the appropriate use of this SIN.

SIN 532289

Leasing

Contact Herman Miller participating government dealer for current leasing information.

1b. Lowest Priced Model

SIN 33721: G9999.B \$10

1c. Not applicable

2. Maximum Order

SIN 33721, 337127, NEW, OLM

\$250,000 net product value

SIN 33721P

\$5,000,000 net value

3. Minimum Order

\$100 net

4. Geographic Coverage

Continental U.S.

Orders for Alaska, Hawaii, and Puerto Rico will be shipped F.O.B. inland carrier point of exportation.

5. Point of Production

Zeeland, Ottawa County, Michigan

Spring Lake, Ottawa County, Michigan

6. Pricing

Prices shown are list. Discounts include Industrial Funding Fee.

SIN 33721

Standard Lead Time, Single Order Net Purchase \$100 - 250,000, includes approved Herman Miller Options Products.

Product Line	Discount From List
Action Office 1	73.8%
Action Office 2	73.8%
Aeron	64.5%
Aside	64.2%
C-Style Overhead Storage	73.8%
Canvas Office Landscape Channel	74.8%
Canvas Office Landscape Dock	74.8%
Canvas Office Landscape Group	74.8%
Canvas Metal Desk	74.8%
Canvas Office Landscape Metal Storage	74.8%
Canvas Office Landscape Private Office	74/8%
Canvas Office Landscape Wood Storage	74.8%
Canvas Office Landscape Vista	74.8%
Canvas Office Landscape Wall	74.8%
Caper	61.5%
Celle	59.7%
Cosm	61.7%
Eames® Conference & Dining Tables	73.6%
Embody	59.7%
Ethospace System	73.8%
Everywhere™ Tables	73.8%
Headway™ Tables	73.8%
Keyn	57.7%
Layout Studio®	60.7%
Lino	63.7%
Meridian Laterals	67.3%
Meridian Pedestals	64.2%
Meridian Towers	62.7%
Meridian Storage	62.7%
Mirra 2	61.7%
Motia Tables	73.8%
Nevi™ Tables	73.8%
Nevi Link	73.8%
OE1 Boundary	72.8%
OE1 Micro Packs	73.8%
OE1 Storage	72.8%
OE1 Tables and Benching	73.8%
Overlay™	62.7%
Plex® Lounge Furniture	59.5%
Renew™ Tables	73.8%
Renew Link	73.8%
Sayl	62.2%
Setu	59.7%
Swoop Lounge Furniture	60.7%
Thrive Portfolio	62.0%
Tu Lateral Files	74.3%
Tu Pedestals	73.8%
Tu Storage	74.3%
Tu Towers	74.3%
Tu Wood Cases	74.3%
Tu Wood Cubbies	74.3%
Tu Wood Credenzas	74.3%
Tu Wood Pedestals	74.3%
Tu Wood Towers	74.3%
Valor™ Family	54.91%
Verus	63.7%
Whisk	54.91%

Contract Information

continued

Services

Please refer to section 19 for Terms and Conditions of Installation/ Reconfiguration and Relocation Services.

Project Management

Services under this SIN may be used only in conjunction with the purchase of new furniture. Please contact your local Herman Miller representative to discuss the available labor categories (listed below). The hourly rates listed are "Not To Exceed" or "NTE" values.

Furniture Project Manager: \$64.75 per hour
 Furniture Project Coordinator: \$49.00 per hour
 Build-Out Project Manager: \$80.00 per hour

Reconfiguration and Relocation Services

Reconfiguration and Relocation Services will be provided by Herman Miller, Inc., or its participating dealer based on a fee not to exceed \$55 per hour.

See * Additional Notes for Installation & Reconfiguration and Relocation Services.

Design/Layout

Design service will be provided by Herman Miller, Inc., or its participating dealer based on a fee not to exceed \$65 per hour.

Installation Services

Installation Services will be provided by Herman Miller, Inc., or its participating dealer based on a fee not to exceed \$55 per hour (\$82.50 per hour for after-hours Installation).

See * Additional Notes for Installation & Reconfiguration and Relocation Services.

SIN 337127

Standard Lead Time, Single Order Net Purchase \$100 - 250,000, includes approved Herman Miller Options Products.

Product Line	Discount From List
Action Lab	58.5%
Compass System	58.5%
Co/Struc System	58.5%
Mora System	58.5%
Bedside Cabinets	58.5%

SIN NEW

Standard Lead Time, Single Order Net Purchase \$100 - 250,000, includes approved Herman Miller Options Products.

Product Line	Discount From List
Commend™ Nurses Station	73.3%
Exclave	61.7%
Intent Solution	58.7%
Locale	63.7%
Public Office Landscape	61.7%
Resolve System	69.8%

SIN 33721P

Packaged Office Furniture - Maximum Order \$5,000,000 (net).

Includes packaged furniture solutions for customers needing to furnish an office.

7. Quantity Discounts

Reference item #6.

8. Payment Terms

Net 30 days

9. Government Commercial Credit Card

- Government commercial credit cards are accepted below the micropurchase threshold.
- Government commercial credit cards are accepted above the micropurchase threshold.

10. Foreign Items

None

11. Time of Delivery

- 90 day ARO
- Expedited delivery: Items listed in the 10-Day section of the catalogs are available for expedited delivery.
- Overnight/2-day delivery: Select items may be available for overnight or 2-day delivery. Contact Herman Miller or a participating dealer for availability and rates.
- Urgent requirements: Agencies may contact contractor or participating dealer to request faster delivery.

12. F.O.B.

F.O.B. destination except Alaska, Hawaii, and Puerto Rico, which will be shipped F.O.B. inland carrier point of exportation.

13. Ordering Address

- Herman Miller, Inc.,
 Government Customer Care 0161
 855 East Main Avenue
 Zeeland MI 49464.
- For supplies and services, the ordering procedures information on Blanket Purchase Agreements (BPA's) are found in Federal Acquisition Regulation (FAR) 8.405-3.

14. Payment Address.

Herman Miller, Inc.
 22764 Network Place
 Chicago, IL 60673-1227

15. Warranty

Herman Miller, Inc., commercial warranty applies.

Contract Information

continued

16. Export Packing Charge

Prices supplied on request.

17. Terms and Conditions of Government Purchase Card Acceptance

Accepted above and below the micropurchase level.

18. Rental Maintenance and Repair Terms

Not applicable

19. Terms and Conditions of Installation/Reconfiguration and Relocation Services

* Additional Notes for Installation & Reconfiguration and Relocation Services:

FOB Destination (Drop Ship): Price includes product delivery to the site, brought to the tailgate of the truck. The purchaser is responsible for unloading.

Prices effective up to the maximum order by SIN only. Above the MO, pricing shall be negotiated on a case-by-case basis between the client and local dealer.

Standard Services are Subject to the Following Conditions:

Installation will be performed during normal weekday working hours.

Adequate facilities for delivery, unloading, moving and staging/storing the product during the installation process shall be provided.

Service work will not be hindered by other trades.

Electric, heat, and adequate elevator service will be furnished without charge.

The immediate installation area shall be complete and free of debris including the carpet/flooring before installation commences.

Any work requiring a licensed electrician is the responsibility of the buyer.

Additional Charges May Apply For:

Major Metro Markets and any non-ground floor installation.

Major Metro Markets include large population centers and urban environments.

Installation in a clinical/medical environment.

Special restrictions or limits established by local laws, ordinances or the directions of the buyer, including but not limited to restrictions on transportations of materials, street access to the job site and/or dock facilities.

Installations outside of a 50 mile radius of the servicing dealer.

Local Prevailing Wage and/or Union Labor Rates.

Any additional charges shall be quoted by the dealer and approved by the buyer prior to performance of the work.

20. Terms and Conditions of Repair Parts

Not applicable

21. Service and Distribution Points

For service and distribution points nearest you, call (800) 851 1196.

22. Participating Dealers

Access Herman Miller web site for current list of participating dealers: www.HermanMiller.com/where-to-buy/contact-a-dealer/. Select your market by using the filter.

23. Preventive Maintenance

Not applicable

24a. Special Attributes.

2019

TIME Magazine names Cosm to its list of the 100 Best Inventions of 2019.

Working Mother Magazine names Herman Miller one of the 100 Best Companies for Working Mothers in 2019.

Herman Miller named #12 Overall and #2 in Manufacturing on Investor's Business Daily Best ESG (Environmental, Social, Governance) Companies.

Herman Miller named Silver Level Employer in the Michigan Veterans Affairs Agency Veteran-Friendly Employer Program.

Herman Miller named "Frontrunner" in Chemical Footprint Project by Clean Production Action for our chemical management policies and practices.

Herman Miller receives International Interior Design Association and Contract's best showroom design award in the "Large Showroom" category at NeoCon.

Herman Miller earns its 12th consecutive perfect score in Human Rights Campaign (HRC) Foundation's 2019 Corporate Equality Index.

Geiger One Caseloads receives a Best of NeoCon Silver in the "Case Goods" category.

Cosm receives a Red Dot Best of the Best Product Design Award in the "Office Chairs" category.

Cosm receives Gold at the New York DRIVENxDESIGN Award in the Product Design—Office category.

Lino receives an iF Design Award in the Product Design category.

2018

Herman Miller receives the Corporation of the Year—Consumer Products award from the Michigan Minority Supplier Development Council.

Herman Miller achieves the Advanced Excellence in Supplier Diversity Award from the Great Lakes Women's Business Council for doing business with women-owned suppliers.

Contract Information

continued

As one of the top-scoring companies in the industry for the fourteenth consecutive year, Herman Miller has qualified for inclusion in RobecoSAM's 2018 Sustainability Yearbook and received the Silver Class distinction for excellent sustainability performance—economic, environmental, and social.

Aeron receives Good Design Award from The Chicago Athenaeum Museum of Architecture and Design.

The Cosm Chair won the 2018 Best of NeoCon Gold Award in the Ergonomic Seating Category, the Interior Design HiP Award in the Ergonomic Seating Category, and a #MetropolisLikes Award. Cosm also won Mix Interiors "Product of the Year—Task" award.

For the 11th consecutive year, Herman Miller received a perfect score on the Corporate Equality Index and we were designated as Best Place to Work for LGBT equality. This report evaluates U.S. companies in terms of diversity, particularly their LGBT-related policies and practices.

2017

Herman Miller was named the 2017 "Corporation of the Year" in the consumer products sector by the Michigan Minority Supplier Development Council (MMSDC).

Herman Miller has received a 2017 SEAL (Sustainability, Environmental Achievement and Leadership) Business Sustainability Award.

Herman Miller has earned the 4 Star Diversity Visionary Award. This award celebrates the diversity, equality, and inclusion work of Herman Miller. The award is presented at the annual Diversity Equity Inclusion Summit, held by the Grand Rapids Area Chamber of Commerce.

Herman Miller named one of the Best and Brightest in Wellness for the fifth year in a row.

Working Mother magazine has recognized Herman Miller as one of the 2017 Working Mother 100 Best Companies.

Herman Miller earned our tenth consecutive perfect score in Human Rights Campaign (HRC) Foundation's 2017 Corporate Equality Index.

As one of the top-scoring companies in our industry for the thirteenth consecutive year, Herman Miller has qualified for inclusion in RobecoSAM's 2017 Sustainability Yearbook and received the Bronze Class distinction for our excellent economic, environmental, and social sustainability performance.

Herman Miller has once again earned the WorldatWork Seal of Distinction, a unique standard of excellence in work-life effectiveness that shows we provide a distinct, mutually beneficial workplace experience.

2016

Herman Miller was recognized as the Business of the Year at the Annual Meeting of the West Michigan Environmental Action Council (WMEAC). This award goes to the business with the greatest depth and breadth of support, unwavering dedication to environmental action in West Michigan, and a strong corporate commitment to environmental advocacy.

The 101 Best and Brightest Sustainable Companies once again (fifth consecutive year) recognized Herman Miller as an organization in Michigan (and for the first time, in the nation) that exhibits leadership and innovation in its approach to sustainability.

Herman Miller has been recognized by the Michigan Minority Supplier Development Council (MMSDC), as a "Corporation of the Year", and we also received a "2016 Excellence in Supplier Diversity Award" from the Great Lakes Women's Business Council. Additionally, we are the only West Michigan company this year to receive an "Ambassadors Championing Excellence" Award from the MMSDC.

Plex Lounge Furniture from Herman Miller receives #MetropolisLikes award at NeoCon 2016.

Plex Lounge Furniture from Herman Miller receives Interior Design HiP Award for Workplace Seating/Lounge at NeoCon 2016.

Spot Stools from Herman Miller Collection receive Interior Design HiP Award for Hospitality Seating at NeoCon 2016.

Herman Miller has been named a 2020 Women on Boards Winning Company. Companies selected for this recognition are considered champions of board diversity as 20 percent or more of their board seats are occupied by women.

Herman Miller selected for inclusion in the 2016 RobecoSAM Sustainability Yearbook for twelfth consecutive year.

Herman Miller again earns the WorldatWork Work-Life 2016 Seal of Distinction. This award identifies organizations that focus on programs that promote work-life balance and overall well-being.

2015

Herman Miller earns ninth consecutive perfect score in Human Rights Campaign (HRC) Foundation's 2016 Corporate Equality Index and we were designated as Best Place to Work for LGBT equality.

This is the fourth consecutive year that Herman Miller was named one of Michigan's Best and Brightest Sustainable Companies.

Herman Miller has received the Best and Brightest in Wellness Award for the third year in a row. This program is an innovative initiative that recognizes and celebrates quality and excellence in health awareness.

Contract Information

continued

Herman Miller received the Forest Stewardship Council® (FSC®) Leadership Award for longstanding commitment to manufacturing with wood sourced from responsibly managed forests, which reduces environmental impacts by protecting against deforestation and forest degradation.

Herman Miller accepted its second Excellence in Reusable Packaging Award from the Reusable Packaging Association.

Herman Miller has once again been recognized for its commitment to best-in-class economic, environmental, and societal sustainability, earning a spot on the prestigious Dow Jones Sustainability Index (DJSI) for the twelfth consecutive year. We are the only contract furniture company recognized globally for its corporate sustainability leadership.

Herman Miller selected for inclusion in the 2015 RobecoSAM Sustainability Yearbook; awarded Bronze Class distinction for excellent sustainability performance for the second consecutive year.

Herman Miller received a Michigan Business Pollution Prevention (MBP₃) Certificate – a recognition given by the Michigan Department of Environmental Quality (MDEQ) to organizations committed to environmental stewardship, conservation, and sustainable operations. This basic partnership with the MDEQ, which we've maintained since 1998, makes us eligible for our Clean Corporate Citizen (CCC) status that began in 2004 and our Environmental Leader status, which we received for the first time this past year.

MedAssets named Herman Miller Healthcare as Platinum Suppliers. MedAssets, a large group purchasing organization, helps providers enhance operational and financial performance so they can sustainably serve the needs of their community.

Herman Miller honored with five of 20 spots for the Michigan Environmental Leaders Award by the Michigan Department of Environmental Quality for our outstanding, voluntary environmental stewardship.

Renew Sit-to-Stand tables recognized on Record Products 2014 list by Architectural Record.

Herman Miller was again awarded a perfect score in the 2015 Corporate Equality Index. This is the eighth consecutive year we received a perfect score.

2014

Herman Miller has received the Best and Brightest in Wellness Award for the second year in a row. This program is an innovative initiative that recognizes and celebrates quality and excellence in health awareness.

Herman Miller's Locale wins International Design Excellence Awards (IDEA) Gold in the Office & Productivity category.

Herman Miller achieves eleventh consecutive listing on Dow Jones Sustainability World Index, an international stock portfolio that evaluates the annual performance of the world's largest 2500 companies using economic, environmental, and social criteria, known as the "triple bottom line" of sustainability.

2013

Herman Miller achieves tenth consecutive listing on Dow Jones Sustainability World Index.

Herman Miller has received the Best and Brightest in Wellness Award. This program is an innovative initiative that recognizes and celebrates quality and excellence in health awareness.

Herman Miller Earns Perfect Score on the Corporate Equality Index. We are one of only 303 major U.S. businesses to receive a perfect score in 2013, an achievement we have now obtained seven years in a row.

Herman Miller is listed in Forbes Magazine inaugural "Platinum List" of America's 400 best managed, large companies.

For the second consecutive year, Herman Miller is honored as one of West Michigan's "101 Best and Brightest Sustainable Companies".

2012

Herman Miller accepted its first Excellence in Reusable Packaging Award from the Reusable Packaging Association.

Herman Miller is named "Corporation of the Year" in the commercial products sector by the Michigan Minority Supplier Development Council.

In July 2012 Herman Miller was inducted into the Made in the USA Hall of Fame. Herman Miller is one of only 20 companies across the nation to receive this distinction.

Herman Miller achieves ninth consecutive listing on Dow Jones Sustainability World Index.

Herman Miller is honored as one of West Michigan's 101 Best and Brightest Sustainable Companies.

The Sustainable Asset Management (SAM) group selected Herman Miller for inclusion in "The Sustainability Yearbook 2012" and has awarded Herman Miller both the "SAM Sector Leader" and "SAM Sector Mover" distinctions.

Herman Miller was named one of 16 Section Leaders on Climate Counts 2011-2012 Scorecard Report, making us the industry leader for Home and office Furnishings.

SGS International Certification Services, Inc., recognizes Herman Miller's manufacturing sites, Midwest Distribution Center, and Design Yard for initial certification to the OHSAS 18001 standard as well as re-certification to ISO 14001.

Contract Information

continued

24b. Section 508 Compliance

Not applicable

25. Data Universal Numbering System (DUNS): 00-601-2801

26. Registered in System for Award Management (www.SAM.gov) Database

27. Cancellation

Prior to production, no cancellation charge will apply. After production, only actual cost incurred that the contractor can demonstrate if items are sold after 3 months.

28. Restocking Charges

Agencies must notify the contractor for authorization prior to returning any items. The customer agency will be required to pay all packaging and return freight charges. A restocking fee of 50% for Systems Furniture and 35% for all other product lines will be charged for any returned items.

Returns and restocking policy is not applicable to products under SIN 337127.

Herman Miller Miscellaneous Information:

Federal ID Number: 38-0837640

Commercial and Government Entity Code (CAGE): 40636

Data Universal Numbering System (DUNS) 00-601-2801

Commercial Entity Code (CEC): 00702290J

Introduction	page 2
Caper® Chairs	3
Multipurpose Chair	5
Multipurpose Stool	7
Stacking Stool	9
Stacking Chairs	11
Stacking Chair with Tablet Arm	15
Storage Baskets	17
Cart	19
Indices	21
By Name	21
By Number	23
Appendices	
20-Day or Less/Assigned Lead-Time Order Information	
Casters and Glides	
Fire Retardancy-Seating	
Proprietary Textiles Application Chart-Seating	
Proprietary Textile Colors-Seating	
For the latest materials information, refer to the Materials pages on HermanMiller.com.	

Introduction

A Note on the Organization of This Book

There are a few signals that will help you understand the organization of this book. Once you know them, you should be able to find your way around easily.

Like a newspaper, this book is formatted with columns of text and illustrations that run vertically.

Information wraps from one column to the next and continues for as many pages as it needs to.

Black bars are clues.

A black bar at the top of a page signals the start of information about a product.

This information is divided into two sections, each signaled by a black bar. Product Information includes a description, additional notes, and dimensional drawings. Specification Information, which always begins at the top of a column, includes a series of steps. Each step represents a decision you need to make in order to complete your product number. Steps must be followed sequentially. The number of pages needed to complete information on a product varies; some will be complete in one page; others may fill three or four pages. Just continue going through the steps until you run into the next product, signaled by the black bar at the top of the page.

Black tabs running along the outside edge of the page help you locate what section you are in or what section you want to go to. You can thumb forwards or backwards to find a section; tabs and text appear on both sides of the page.

The additional pages in the back of the book include the appendices and indices. They are signaled by a long black bar running along the outside edge of the page.

The index is presented two ways.

The first index is in alphabetical order by product name. It can be helpful if you are new to the products and numbering scheme or if you are looking for a type of product, such as work chair or round table.

The second index is by product number. It lists, in alphanumeric order, the base product number, typically a five-digit number.

General Information

This book is effective April 6, 2020, subject to change without notice. Products may be purchased from authorized Herman Miller dealers who will quote prices upon request. For more information about our products and services or to see a list of dealers, visit www.HermanMiller.com.

All prices are list prices. Additional services, such as planning services, design, storage, and installation, are not included and must be added to these prices when the additional services are requested.

Illustrations, specifications, and prices are based on the latest information at the time of publication. The right is reserved to make changes at any time without notice in prices, fabrics, finishes, materials, specifications, and models, and also to discontinue models and finishes.

Dimensions shown in the drawings are engineering drawing dimensions rounded up to the nearest $\frac{1}{8}$ ". Product is shipped set up or knocked down. Products that include "Shipped knocked down" in the description require some assembly. If this statement does not appear in the description, the product is shipped assembled.

Service problems are normally handled by a Herman Miller authorized dealer. Where this cannot be accomplished on a local level, service problems should be referred to the Customer Care Representative for your region, Herman Miller, Inc., Zeeland, Michigan 49464.

20-Day or Less/Assigned Lead-Time Shipments

All products and options in this price book not designated by an Assigned Program icon  will ship in **20 business days or less** after being acknowledged by Herman Miller.

Products and options designated by an  are on the assigned lead-time program and may ship in 20 days, less than 20 days, or more than 20 days from order acknowledgement.

Multipurpose Chair

Multipurpose Stools

Stacking Chairs

Cart

Multipurpose Chair

WC111
WC121



Product Information

Description

This multipurpose chair has a molded, flexible back that is perforated and contoured. It has a biomechanical tilt mechanism that synchronizes the movement of the chair's seat and back, pneumatic seat-height adjustment, and 5-star base with casters. The chair has 2 seat options: the molded seat is perforated and contoured; the Flexnet™ seat is suspension material. It is available with or without arms.

The multipurpose chair is breathable and distributes the user's weight evenly. Each chair is lightweight and mobile and has a cutout in the back for easy movement.

Notes

Caper® chairs are not recommended for outdoor use.

MicrobeCare™ is an antimicrobial coating that can be applied to a wide variety of Herman Miller Group surfaces to protect products from mold, mildew, algae, and bacteria that cause deterioration, discoloration, odors, and stains.

MicrobeCare™ is a US Environmental Protection Agency (EPA) registered nonpublic health antimicrobial.

MicrobeCare™ is applied to the major touchpoints, including the seat, backrest, arms, armrests, frame and adjustment controls.

For information on casters, see Casters and Glides in Appendices.

Dimensions

Molded Seat

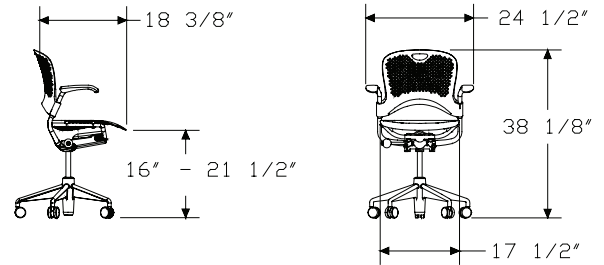

FLEXNET Seat

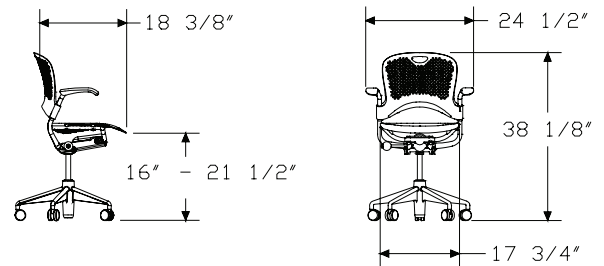

Multipurpose Chair *continued*

Caper® Multipurpose Chair

Specification Information

Step 1.

WC1

Step 2. Seat Style

11	molded seat	+\$700
21	flexnet™ seat	+\$860

Step 3. Arms

N	no arms	+\$0
P	fixed arms	+\$100

Step 4. Frame Finish

BK	black	+\$0
MS	metallic silver	+\$20

Step 5. Seat/Back Finish

3M	berry blue	+\$0
63	fog	+\$0
79	green apple	+\$0
98	studio white	+\$0
BK	black	+\$0
G1	graphite	+\$0
LMN	lemon	+\$0
RO	red	+\$0
TRQ	turquoise	+\$0
ZK	cappuccino	+\$0

Step 6. Casters

BB	2½" hard caster, black yoke, carpet only	+\$0
C7	2½" caster, black yoke, hard floors or carpet	+\$40
C9	2½" braking caster, black yoke, hard floors or carpet	+\$50

Step 7. Arm Finish/Arm Cap Finish

For no arms (N)

63	fog	+\$0
BK	black	+\$0
SY	silver grey	+\$0

For fixed arms (P)

63	fog	+\$0
BK	black	+\$0
SY	silver grey	+\$0

Step 8. Flexnet™ Material

For flexnet™ seat (21)

See application chart and textiles list for fabric usage and numbers.

First 2 digits of number indicate fabric line; remaining digit(s) indicate fabric color.

Price Category 1 +\$0

Caper® Multipurpose Stool

WC751
WC752



Product Information

Description

This multipurpose stool has a molded, flexible back that is perforated and contoured. It has a biomechanical tilt mechanism that synchronizes the movement of the stool's seat and back, pneumatic height adjustment and 5-star base. The stool has 2 seat options: the molded seat is perforated and contoured; the Flexnet™ seat is suspension material. It is available with or without arms.

The stool is breathable and distributes the user's weight evenly.

Notes

Footrest available in trivalent chrome; column and ring support are black.

Caper® multipurpose stools are not recommended for outdoor use.

MicrobeCare™ is an antimicrobial coating that can be applied to a wide variety of Herman Miller Group surfaces to protect products from mold, mildew, algae, and bacteria that cause deterioration, discoloration, odors, and stains.

MicrobeCare™ is a US Environmental Protection Agency (EPA) registered nonpublic health antimicrobial.

MicrobeCare™ is applied to the major touchpoints, including the seat, backrest, arms, armrests, frame and adjustment controls.

For information on casters, see Casters and Glides in Appendices.

Dimensions

Molded Seat

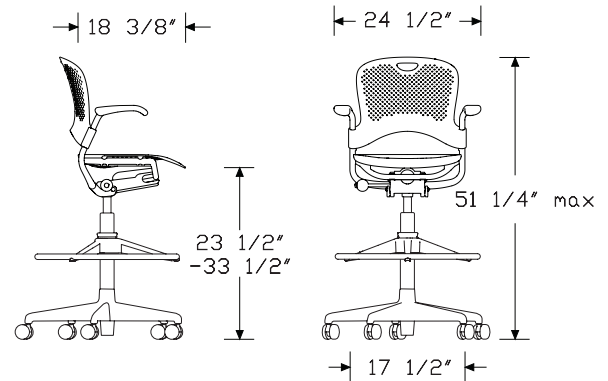

Flexnet Seat

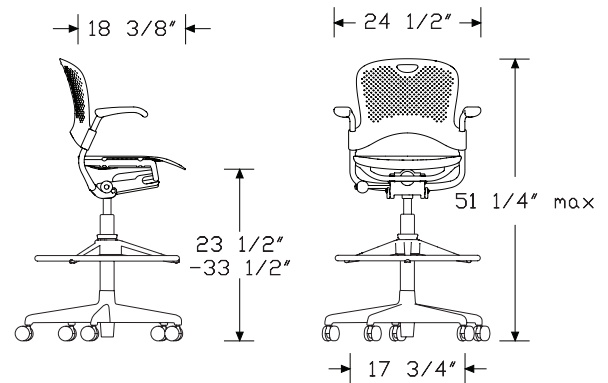

Caper® Multipurpose Stool *continued*

Caper® Multipurpose Stools

Specification Information		
Step 1.		
WC7		
Step 2. Height Adjustment		
5	5-star base, stool height range	+\$963
Step 3. Seat Style		
11	molded seat	+\$0
21	flexnet™ seat	+\$160
Step 4. Arms		
N	no arms	+\$0
P	fixed arms	+\$100
Step 5. Frame Finish		
BK	black	+\$0
MS	metallic silver	+\$20
Step 6. Seat/Back Finish		
3M	berry blue	+\$0
63	fog	+\$0
79	green apple	+\$0
98	studio white	+\$0
BK	black	+\$0
G1	graphite	+\$0
LMN	lemon	+\$0
RO	red	+\$0
TRQ	turquoise	+\$0
ZK	cappuccino	+\$0
Step 7. Casters/Glides		
BB	2½" hard caster, black yoke, carpet only	+\$0
C7	2½" caster, black yoke, hard floors or carpet	+\$40
C9	2½" braking caster, black yoke, hard floors or carpet	+\$40
GF	2½" glide, hard floors or carpet	+\$0
Step 8. Arm Finish/Arm Cap Finish		
<i>For no arms (N)</i>		
63	fog	+\$0
BK	black	+\$0
SY	silver grey	+\$0

<i>For fixed arms (P)</i>		
63	fog	+\$0
BK	black	+\$0
SY	silver grey	+\$0
Step 9. Flexnet™ Material		
<i>For flexnet™ seat (21)</i>		
<i>See application chart and textiles list for fabric usage and numbers.</i>		
<i>First 2 digits of number indicate fabric line; remaining digit(s) indicate fabric color.</i>		
Price Category 1		+\$0

Caper® Stacking Stool

WC742
WC743

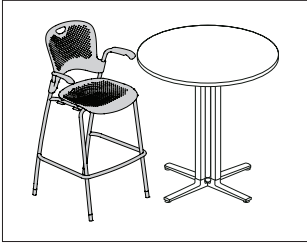

Product Information

Description

This stacking stool has a molded, flexible back that is perforated and contoured. The stool has a tubular steel frame and foot ring and comes in 24" (counter) and 30" (bar) heights. Available with or without arms. The stool has 2 seat options: the molded seat is perforated and contoured; the Flexnet™ seat is suspension material. Each stool is breathable and distributes the users weight evenly. The stool is lightweight and mobile. The 24" stool weighs 13.8 pounds and the 30" stool weighs 14.9 pounds. All styles of this stool can be stacked up to 5 high on the floor. Each seat back has a cutout for easy movement.

Notes

Caper stacking stools are not recommended for outdoor use. Glide color is predetermined based on arm finish/arm cap finish. For black (BK) and silver grey (SY), glides are black. For fog (63), glides are fog (63). MicrobeCare™ is an antimicrobial coating that can be applied to a wide variety of Herman Miller Group surfaces to protect products from mold, mildew, algae, and bacteria that cause deterioration, discoloration, odors, and stains. MicrobeCare™ is a US Environmental Protection Agency (EPA) registered nonpublic health antimicrobial. MicrobeCare™ is applied to the major touchpoints, including the seat, backrest, arms, armrests, and frame. For information on casters and glides, see Casters and Glides in appendices.

Dimensions

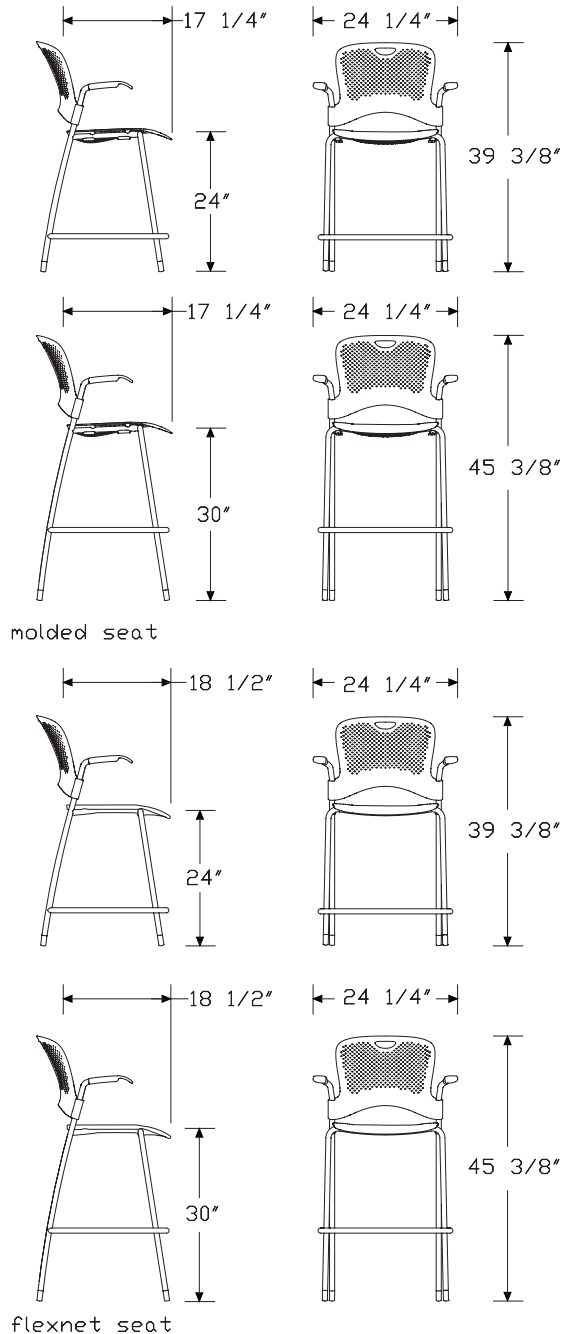

Caper® Multipurpose Stools

Caper® Stacking Stool *continued*

Caper® Multipurpose Stools

Specification Information		
Step 1.		
WC7		
Step 2. Height Adjustment		
424	4-leg base, counter height range	+\$490
430	4-leg base, bar height range	+\$490
Step 3. Seat Style		
10	molded seat	+\$0
20	flexnet™ seat	+\$160
Step 4. Arms		
N	no arms	+\$0
P	fixed arms	+\$100
Step 5. Frame Finish		
BK	black	+\$0
MS	metallic silver	+\$20
Step 6. Seat/Back Finish		
3M	berry blue	+\$0
63	fog	+\$0
79	green apple	+\$0
98	studio white	+\$0
BK	black	+\$0
G1	graphite	+\$0
LMN	lemon	+\$0
RO	red	+\$0
TRQ	turquoise	+\$0
ZK	cappuccino	+\$0
Step 7. Casters/Glides		
Y7	acetal glide, carpet only	+\$0
YX	Floor Saver Glide® insert, hard floors only	+\$25
Step 8. Arm Finish/Arm Cap Finish		
63	fog	+\$0
BK	black	+\$0
SY	silver grey	+\$0
Step 9. Flexnet™ Material		
<i>For flexnet™ seat (20)</i>		
<i>See application chart and textiles list for fabric usage and numbers.</i>		
<i>First 2 digits of number indicate fabric line; remaining digit(s) indicate fabric color.</i>		
Price Category 1		+\$0

Stacking Chair

WC410
WC420

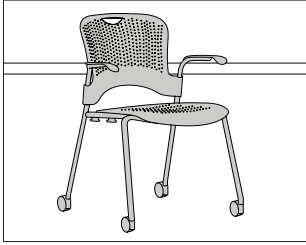

Product Information

Description

This stacking chair has a tubular steel frame, a molded back that is perforated and contoured, and a 4-leg base with casters or glides. It has 2 seat options: the molded seat is perforated and contoured; the Flexnet™ seat is suspension material. Each chair is breathable and distributes the user's weight evenly. The chair is available with or without arms.

The chair is lightweight and mobile. The molded chair without arms weighs 9½ pounds and the Flexnet chair with arms weighs 11½ pounds. All styles of this chair can be stacked up to 6-chairs high on the floor and up to 15-chairs high on the Caper® cart. Each chair has a cutout in the back for easy movement.

Notes

Ganging stacking chairs (WC415 or WC425) can be stacked with armless stacking chairs (WC410N or WC420N) on the floor or on a Caper cart.

Caper chairs with installed storage basket will not stack. Order storage basket (WC6) separately.

Order optional Caper cart (WC904) separately.

Caper chairs are not recommended for outdoor use.

Glide color is predetermined based on arm finish/arm cap finish. For black (BK) and silver grey (SY), glides are black. For fog (63), glides are fog (63).

MicrobeCare™ is an antimicrobial coating that can be applied to a wide variety of Herman Miller Group surfaces to protect products from mold, mildew, algae, and bacteria that cause deterioration, discoloration, odors, and stains.

MicrobeCare™ is a US Environmental Protection Agency (EPA) registered nonpublic health antimicrobial.

MicrobeCare™ is applied to the major touchpoints, including the seat, backrest, arms, armrests, and frame.

For information on casters and glides, see Casters and Glides in Appendices.

Dimensions

Molded Seat

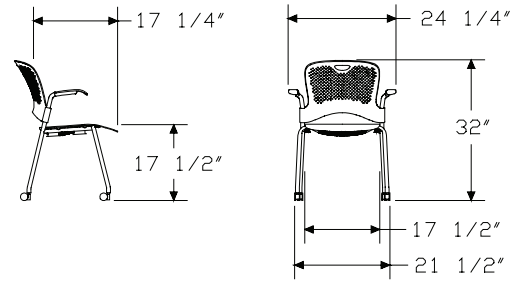

FLEXNET Seat

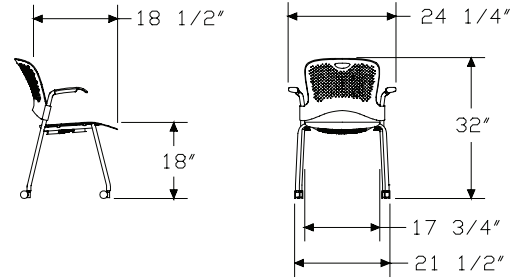

Stacking Chair *continued*

Specification Information		
Step 1.		
WC4		
Step 2. Seat Style		
10	molded seat	+\$254
20	flexnet™ seat	+\$414
Step 3. Arms		
N	no arms	+\$0
P	fixed arms	+\$100
Step 4. Frame Finish		
BK	black	+\$0
MS	metallic silver	+\$20
Step 5. Seat/Back Finish		
3M	berry blue	+\$0
63	fog	+\$0
79	green apple	+\$0
98	studio white	+\$0
BK	black	+\$0
G1	graphite	+\$0
LMN	lemon	+\$0
RO	red	+\$0
TRQ	turquoise	+\$0
ZK	cappuccino	+\$0
Step 6. Casters/Glides		
Y7	acetal glide, carpet only	+\$0
YX	Floor Saver Glide® insert, hard floors only	+\$25
U5	soft wheel caster, carpet or hard floors	+\$30
DS	2" soft double wheel braking caster, hard floors	+\$30
Step 7. Arm Finish/Arm Cap Finish		
63	fog	+\$0
BK	black	+\$0
SY	silver grey	+\$0
Step 8. Flexnet™ Material		
<i>For flexnet™ seat (20)</i>		
<i>See application chart and textiles list for fabric usage and numbers.</i>		
<i>First 2 digits of number indicate fabric line; remaining digit(s) indicate fabric color.</i>		
	Price Category 1	+\$0

Ganging Stacking Chair

WC415
WC425

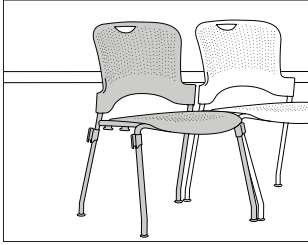

Product Information

Description

This ganging stacking chair has a tubular steel frame, a molded back that is perforated and contoured, and a 4-leg base with glides. It has 2 seat options: the molded seat is perforated and contoured; the Flexnet™ seat is suspension material. Each chair is breathable and distributes the user's weight evenly. The chair's ganging connectors are on the front and rear legs to ensure proper alignment.

The chair is lightweight and mobile and weighs 9½ pounds. It can be stacked up to 6-chairs high on the floor and up to 15-chairs high on the Caper® cart. Each chair has a cutout in the back for easy movement.

Notes

Ganging connector finish matches frame finish.

Ganging stacking chairs (WC415 or WC425) can be stacked with armless stacking chairs (WC410N or WC420N) on the floor or on a Caper cart.

Caper chairs with installed storage basket will not stack. Order storage basket (WC6) separately.

Order optional Caper cart (WC904) separately.

Caper chairs are not recommended for outdoor use.

Glide color is predetermined based on arm finish/arm cap finish. For black (BK) and silver grey (SY), glides are black. For fog (63), glides are fog (63).

MicrobeCare™ is an antimicrobial coating that can be applied to a wide variety of Herman Miller Group surfaces to protect products from mold, mildew, algae, and bacteria that cause deterioration, discoloration, odors, and stains.

MicrobeCare™ is a US Environmental Protection Agency (EPA) registered nonpublic health antimicrobial.

MicrobeCare™ is applied to the major touchpoints, including the seat, backrest, arms, armrests, and frame.

For information on glides, see Casters and Glides in Appendices.

Dimensions

Molded Seat

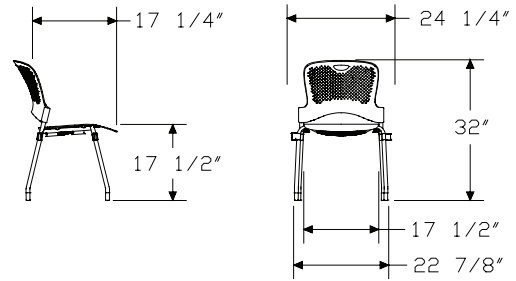

FLEXNET Seat

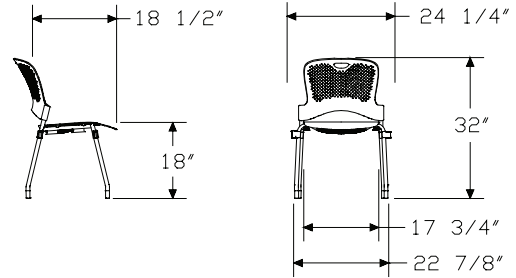

Ganging Stacking Chair *continued*

Specification Information		
Step 1.		
WC4		
Step 2. Seat Style		
15N	molded seat	+\$293
25N	flexnet™ seat	+\$453
Step 3. Frame Finish		
BK	black	+\$0
MS	metallic silver	+\$20
Step 4. Seat/Back Finish		
3M	berry blue	+\$0
63	fog	+\$0
79	green apple	+\$0
98	studio white	+\$0
BK	black	+\$0
G1	graphite	+\$0
LMN	lemon	+\$0
RO	red	+\$0
TRQ	turquoise	+\$0
ZK	cappuccino	+\$0
Step 5. Glide Option		
Y7	acetal glide, carpet only	+\$0
YX	Floor Saver Glide® insert, hard floors only	+\$25
Step 6. Arm Cap Finish		
63	fog	+\$0
BK	black	+\$0
SY	silver grey	+\$0
Step 7. Flexnet™ Material		
<i>For flexnet™ seat (25N)</i>		
<i>See application chart and textiles list for fabric usage and numbers.</i>		
<i>First 2 digits of number indicate fabric line; remaining digit(s) indicate fabric color.</i>		
Price Category 1		+\$0

Stacking Chair with Tablet Arm

WC510
WC520

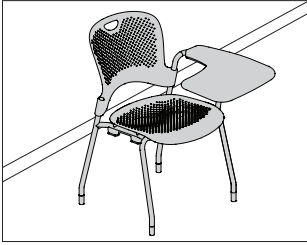

Product Information

Description

This stacking chair with tablet arm has a tubular steel frame, a molded back that is perforated and contoured, and a 4-leg base with glides. It has 2 seat options: the molded seat is perforated and contoured; the Flexnet™ seat is suspension material. Each chair is breathable and distributes the user's weight evenly. The tablet arm can be specified on the left or right side.

The tablet is wood and flat, and available in a variety of laminate options. It is 17⁷/₈"W x 20⁷/₈"D. The tablet has a built-in dampener that prevents the tablet from falling down when extended.

This stacking chair with tablet can be stacked up to 3-chairs high on the floor or on the Caper® cart. Each chair has a cutout in the back for easy movement.

Tablet ships unassembled to the chair to prevent damage during shipping.

The tablet fully extends to 135° in the up position for ease of getting into and out of the chair.

Notes

Footprint of chair with tablet in down position is 32"H x 25"W x 31¹/₂"D.

Footprint of chair with tablet fully extended in up position is 32"H x 35"W x 31¹/₂"D.

Do not sit on or stack heavy objects on tablet arm. Product could tip and cause injury.

Chair with tablet cannot be ganged together.

Order optional Caper cart (WC904) separately.

Caper chairs are not recommended for outdoor use.

MicrobeCare™ is an antimicrobial coating that can be applied to a wide variety of Herman Miller Group surfaces to protect products from mold, mildew, algae, and bacteria that cause deterioration, discoloration, odors, and stains.

MicrobeCare™ is a US Environmental Protection Agency (EPA) registered nonpublic health antimicrobial.

MicrobeCare™ is applied to the major touchpoints, including the seat, backrest, arms, armrests, and frame.

For information on glides, see Casters and Glides in appendices.

Dimensions

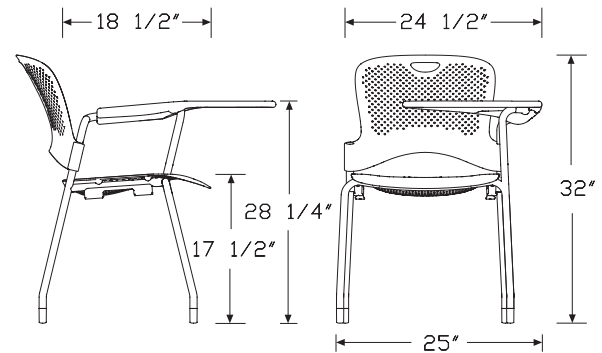

Moulded Seat

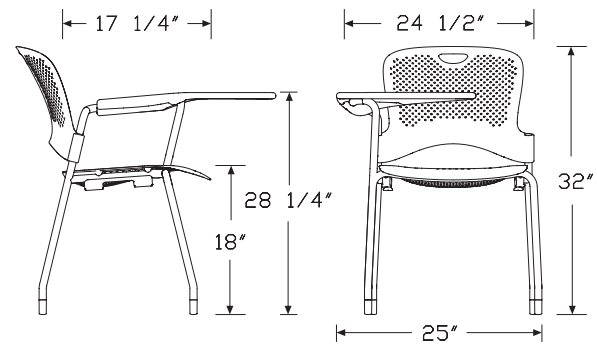

Flexnet Seat

Caper® Stacking Chairs

Stacking Chair with Tablet Arm

continued

Caper® Stacking Chairs

Specification Information		
Step 1.		
WC5	<input type="checkbox"/>	
Step 2. Seat Style		
10	molded seat <input type="checkbox"/>	+\$572
20	flexnet™ seat <input type="checkbox"/>	+\$732
Step 3. Tablet Arm Orientation		
L	tablet arm left <input type="checkbox"/>	+\$0
R	tablet arm right <input type="checkbox"/>	+\$0
Step 4. Frame Finish		
BK	black <input type="checkbox"/>	+\$0
MS	metallic silver <input type="checkbox"/>	+\$20
Step 5. Seat/Back Finish		
3M	berry blue	+\$0
63	fog <input type="checkbox"/>	+\$0
79	green apple <input type="checkbox"/>	+\$0
98	studio white <input type="checkbox"/>	+\$0
BK	black <input type="checkbox"/>	+\$0
G1	graphite <input type="checkbox"/>	+\$0
LMN	lemon <input type="checkbox"/>	+\$0
RO	red <input type="checkbox"/>	+\$0
TRQ	turquoise <input type="checkbox"/>	+\$0
ZK	cappuccino <input type="checkbox"/>	+\$0
Step 6. Glides		
Y7	acetal glide, carpet only <input type="checkbox"/>	+\$0
YX	Floor Saver Glide® insert, hard floors only <input type="checkbox"/>	+\$25
Step 7. Arm Finish/Arm Cap Finish		
63	fog <input type="checkbox"/>	+\$0
BK	black <input type="checkbox"/>	+\$0
SY	silver grey <input type="checkbox"/>	+\$0

Step 8. Tablet Finish		
76	light brown walnut <input type="checkbox"/>	+\$0
8Q	folkstone grey <input type="checkbox"/>	+\$0
91	white <input type="checkbox"/>	+\$0
98	studio white <input type="checkbox"/>	+\$0
BU	black umber <input type="checkbox"/>	+\$0
CL	cool grey neutral <input type="checkbox"/>	+\$0
HF	inner tone light <input type="checkbox"/>	+\$0
HM	natural maple <input type="checkbox"/>	+\$0
HP	light anigre <input type="checkbox"/>	+\$0
HX	aged cherry <input type="checkbox"/>	+\$0
HY	walnut on cherry <input type="checkbox"/>	+\$0
LA	light ash <input type="checkbox"/>	+\$0
LBA	clear on ash <input type="checkbox"/>	+\$0
LBB	oak on ash <input type="checkbox"/>	+\$0
LBC	walnut on ash <input type="checkbox"/>	+\$0
LBD	dark brown walnut <input type="checkbox"/>	+\$0
LBF	neutral twill <input type="checkbox"/>	+\$0
LBG	sarum twill <input type="checkbox"/>	+\$0
LBH	earthen twill <input type="checkbox"/>	+\$0
LBJ	graphite twill <input type="checkbox"/>	+\$0
LBM	crisp linen <input type="checkbox"/>	+\$0
LBN	classic linen <input type="checkbox"/>	+\$0
LBP	casual linen <input type="checkbox"/>	+\$0
LBQ	white twill <input type="checkbox"/>	+\$0
LT	light tone <input type="checkbox"/>	+\$0
LU	soft white <input type="checkbox"/>	+\$0
WL	sandstone <input type="checkbox"/>	+\$0
WN	warm grey neutral <input type="checkbox"/>	+\$0
Step 9. Flexnet™ Material		
<i>For flexnet™ seat (20)</i>		
<i>See application chart and textiles list for fabric usage and numbers.</i>		
<i>First 2 digits of number indicate fabric line; remaining digit(s) indicate fabric color.</i>		
Price Category 1	<input type="checkbox"/>	+\$0

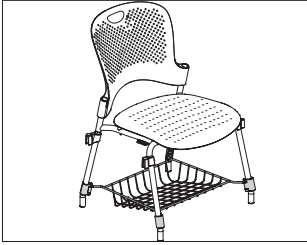

Product Information

Description

This storage basket installs in the field to all models of new or existing Caper® stacking chairs. Basket shape and wire mesh design prevent items from falling off or sliding back. Ships unassembled from the chair. Package contains 1 storage basket.

Notes

- Basket maximum weight capacity is 30 pounds.
- Specify basket finish to match chair frame finish.
- Caper chairs with installed storage basket will not stack.
- Order stacking chairs separately:
 - Stacking chair (WC410, WC420)
 - Ganging stacking chair (WC415N, WC425N)
 - Stacking chair with tablet arm (WC510, WC520)

Dimensions

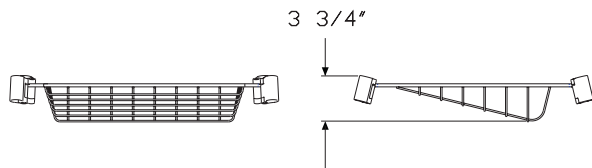
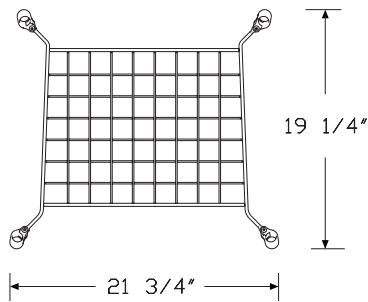

Specification Information

Step 1.

WC6 A

Step 2. Quantity per Box

01 one storage basket per box A +\$93

Step 3. Finish

BK black A +\$0

MS metallic silver A +\$0

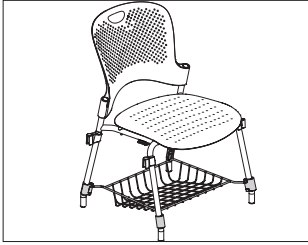

Caper® Stacking Chairs

Product Information

Description
 This storage basket installs in the field to all models of new or existing Caper® stacking chairs. Basket shape and wire mesh design prevent items from falling off or sliding back. Ships unassembled from the chair. Package contains 4 storage baskets.

Notes

- Basket maximum weight capacity is 30 pounds.
- Specify basket finish to match chair frame finish.
- Caper chairs with installed storage basket will not stack.
- Order stacking chairs separately:
 - Stacking chair (WC410, WC420)
 - Ganging stacking chair (WC415N, WC425N)
 - Stacking chair with tablet arm (WC510, WC520)

Dimensions

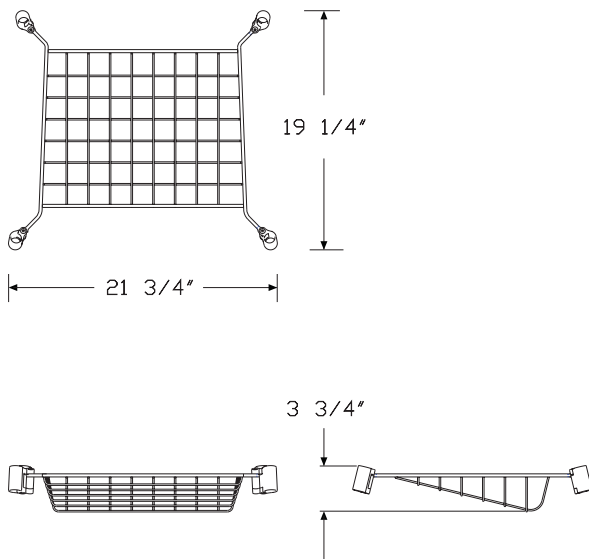

Specification Information

Step 1.

WC6 A

Step 2. Quantity per Box

04 four storage baskets per box A +\$359

Step 3. Finish

BK black A +\$0

MS metallic silver A +\$0

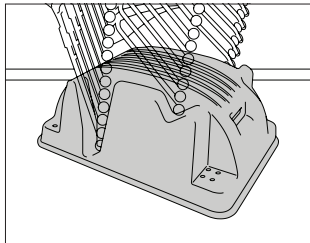

Product Information

Description

This cart stores and transports up to 15 Caper® stacking chairs or ganging stacking chairs, or up to 3 Caper stacking chairs with tablet arm. It has molded-in handles and 4"-diameter casters: 2 swivel and 2 rigid. The cart is single-piece-molded construction that ships fully assembled. Finish is black.

Notes

Ganging stacking chairs (WC415 or WC425) can be stacked with armless stacking chairs (WC410N or WC420N).

Caper stacking chairs with tablet arm (WC510 or WC520) can be stacked only with other Caper stacking chairs with tablet arm.

Dimensions

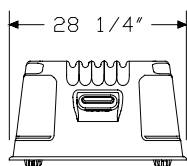
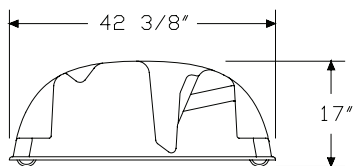

Specification Information

Step 1.

WC904

\$529

Index by Product Name

Caper® Chairs	
Caper® Cart	page(s) 19
Caper® Multipurpose Stool	7
Caper® Stacking Stool	9
Caper® Storage Basket	17
Caper® Storage Baskets	18
Ganging Stacking Chair	13
Multipurpose Chair	5
Stacking Chair	11
Stacking Chair with Tablet Arm	15

Index: Product Name



Index by Product Number



WC111 Multipurpose Chair	page(s) 5
WC121	
WC410 Stacking Chair	11
WC415 Ganging Stacking Chair	13
WC420 Stacking Chair	11
WC425 Ganging Stacking Chair	13
WC510 Stacking Chair with Tablet Arm	15
WC520	
WC601 Caper® Storage Basket	17
WC604 Caper® Storage Baskets	18
WC742 Caper® Stacking Stool	9
WC743	
WC751 Caper® Multipurpose Stool	7
WC752	
WC904 Caper® Cart	19



20-Day or Less/Assigned Lead-Time Order Information

20-Day or Less and Assigned Lead-Time Programs

20-day or less and assigned lead-time products are designed for established Herman Miller dealers with pre-approved credit.

Products are distributed from multiple manufacturing facilities across the United States. All products and options not designated by an Assigned Lead-Time icon  will ship in 20 business days or less after being acknowledged by Herman Miller. Products and options designated by an  are on the assigned lead-time program and will ship in 20 days, less than 20 days, or more than 20 days from order acknowledgement.

Ordering Procedure

Please place orders through Order Manager. If this is not available to you, place orders through mail or fax. Verbal purchase orders will not be accepted.

Order Entry fax number for Passage®, 5000 Series, and Meridian® Filing and Storage: (616) 846 9236.

Order Entry fax number for all other products:
(616) 654 3085.

For more information, contact your Customer Care representative at:
(866) 854 3048 EXT 3400.

Shipments and Delivery

Per Herman Miller Terms and Conditions.

Changes and Cancellation

Per Herman Miller Terms and Conditions.



Casters and Glides

⚠	WARNING	⚠
Depending on the floor surface, chair may unexpectedly roll away from user when entering or exiting the chair, possibly leading to unexpected injury. Please refer to descriptions of floor types when selecting casters.		



17/8-inch-diameter hard double-wheel caster; black nylon wheels and yoke; for use on carpet only
 Applicable on:
 Sayl® Chairs

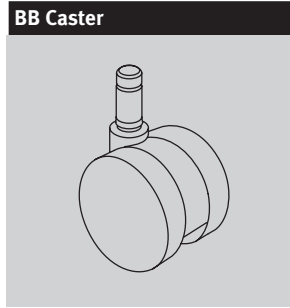

2 1/2-inch-diameter hard double-wheel caster; black nylon wheels and yoke; for use on carpet only
 Applicable on:
 New Aeron® Chairs
 Caper® Chairs
 Celle® Chairs
 Embody® Chairs
 Equa 2® Chairs
 Ergon 3® Chairs
 Lino™ Chairs
 Mirra® 2 Chairs
 Sayl Chairs Verus™ Chairs

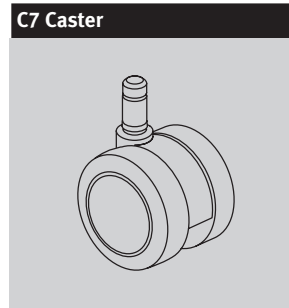

2 1/2-inch-diameter double-wheel caster; black nylon wheels and yoke; soft polyurethane tread; for use on hard floors or carpet
 Applicable on:
 New Aeron Chairs
 Caper Chairs
 Celle Chairs
 Embody Chairs
 Equa 2 Chairs
 Ergon 3 Chairs
 Lino Chairs
 Mirra 2 Chairs
 Sayl Chairs Verus Chairs

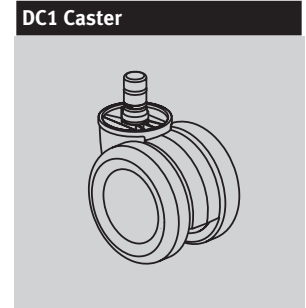

2 1/2-inch-diameter double-wheel braking caster; black nylon wheels and yoke; for use on hard floors or carpet; quiet roll technology
 Applicable on:
 New Aeron Chairs

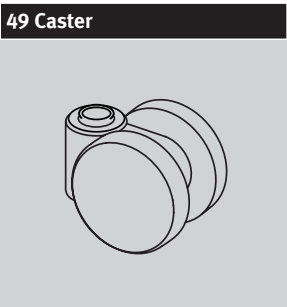

1 7/8-inch-diameter soft double-wheel caster; black nylon wheels and yoke; for use on hard floors or carpet
 Applicable on:
 Sayl Chairs



2 1/2-inch-diameter hard double-wheel caster; black yoke; quiet roll technology; for use on carpet only
 Applicable on:
 Cosm™ Chairs

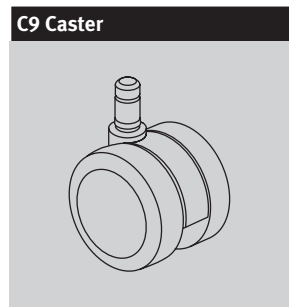

2 1/2-inch-diameter double-wheel caster; black nylon wheels and yoke; soft polyurethane tread; internal brake; for use on hard floors or carpet
 Applicable on:
 Caper Chairs
 Celle Chairs
 Embody Chairs
 Equa 2 Chairs Mirra 2 Chairs
 Ergon 3 Chairs Sayl Chairs
 Keyn Chairs Setu Chairs
 Lino Chairs Verus Chairs

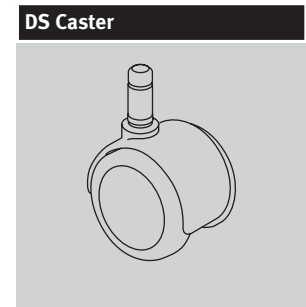

2-inch-diameter soft double-wheel braking caster; black nylon wheels and hood; for use on hard floors only
 Applicable on:
 Aside® Chairs
 Caper Chairs

Casters and Glides

continued

H9 Caster

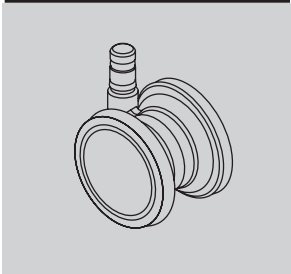

2 1/2-inch-diameter double-wheel caster; clear polycarbonate wheels; nylon yoke; soft polyurethane tread; for use on carpet only.

Applicable on:
Embody Chairs

OC Caster



2 1/2-inch-diameter double-wheel medium roll-resistant caster; black nylon wheels and yoke; soft polyurethane tread; for use on hard floors or carpet; quiet roll technology

Applicable on:
Cosm Chairs
Keyn Chairs
Setu Chairs

U4 Caster

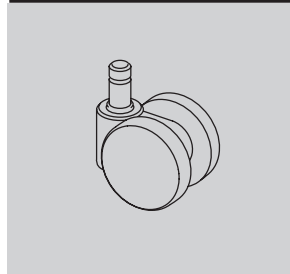

1 7/8-inch-diameter hard double-wheel caster; black nylon wheels and yoke; for use on carpet only

Applicable on:
Aside Chairs
Verus Chairs

16 Glide

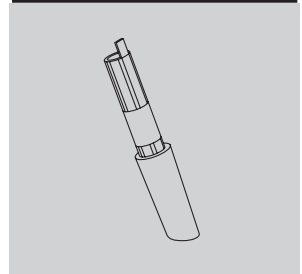

(Front glide shown)
2 1/8-inch-high glide; black or fog acetal; for use on carpet only
Applicable on:
Sayl Chairs

HCC Caster

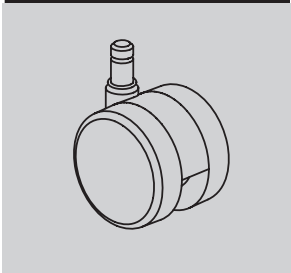

2 1/2-inch-diameter double-wheel low roll resistance caster; black nylon wheels and yoke; for use on hard floors or carpet.

Applicable on:
Keyn Chairs
Setu Chairs

SC8 Caster

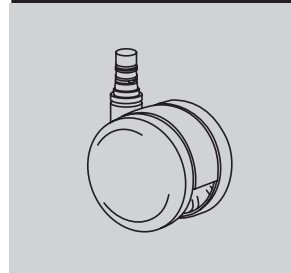

2 1/2-inch-diameter double-wheel caster; black nylon wheels and yoke; soft polyurethane tread; quiet roll technology; for use on hard floors or carpet

Applicable on:
Cosm Chairs
Lino Chairs
Mirra 2 Chairs
Verus Chairs

U5 Caster

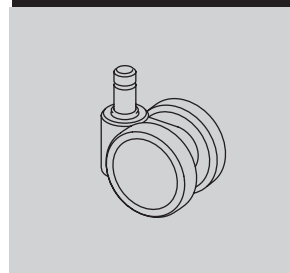

1 7/8-inch-diameter soft double-wheel caster; black nylon wheels and yoke; for use on hard floors or carpet

Applicable on:
Aside Chairs
Caper Chairs
Verus Chairs

69 Glide

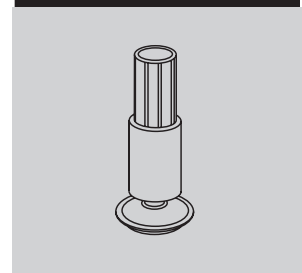

(Front glide shown)
2 1/8-inch-high glide; black glass-filled nylon stem; steel-plated swivel foot with Floor Saver Glide® insert; for use on hard floors only
Applicable on:
Sayl Chairs

Casters and Glides

continued

G4 Glide

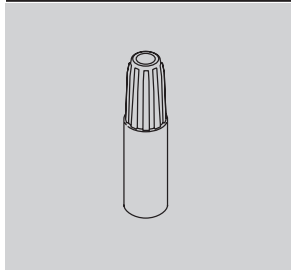

17/8-inch-high glide; black acetal; for use on carpet only
 Applicable on:
 Verus Chairs

GL Glide

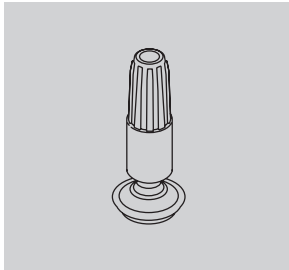

17/8-inch-high glide; black nylon stem; steel-plated swivel foot with Floor Saver Glide® insert; for use on hard floors only
 Applicable on:
 Verus Chairs

SB Glide

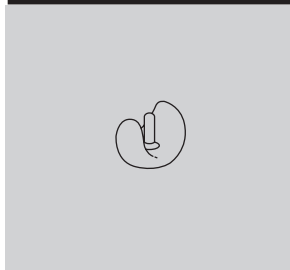

1/4-inch-high, 1-inch diameter glide; thermoplastic CAP material (G1 base has black glides; XT base has clear glides); for use on hard floors or carpet
 Applicable on:
 Equa 2 Chairs

X8 Glide

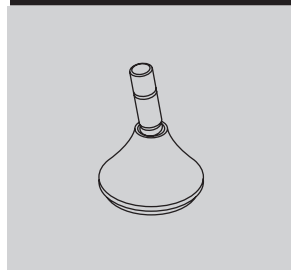

Glide; low profile; for use on hard floors or carpet
 Applicable on:
 Setu Chairs

GF Glide

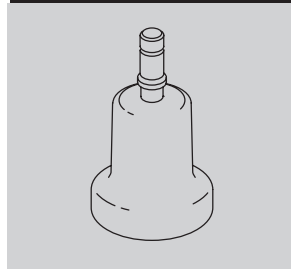

2 1/2-inch-high glide; black nylon; for use on hard floors or carpet
 Applicable on:
 New Aeron Chairs
 Caper Chairs
 Celle Chairs
 Cosm Chairs
 Equa 2 Chairs
 Ergon 3 Chairs
 Lino Chairs
 Mirra 2 Chairs
 Sayl Chairs
 Verus Chairs

HG Glide

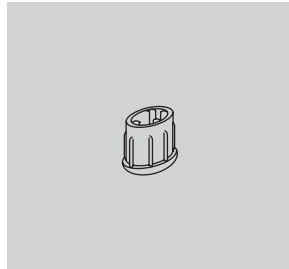

1/2-inch-high glide; black nylon glide with stainless-steel insert; for use on hard floors or carpet
 Applicable on:
 Aside Chairs

SG Glide (for Aside)

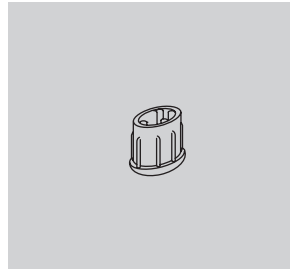

1/2-inch-high glide; black nylon; for use on carpet only
 Applicable on:
 Aside Chairs

XS Glide

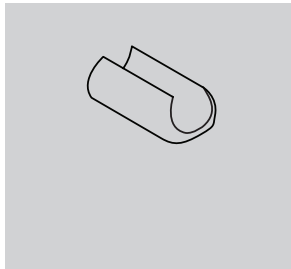

1/8-inch-high glide; polycarbonate in black, fog, clear, and studio white finishes; for use on hard floors or carpet
 Applicable on:
 Sayl Chairs

Casters and Glides

continued

Y7 Glide

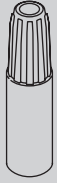

1 7/8-inch-high glide; black acetal; for use on carpet only

Applicable on:

Caper Chairs

YX Glide

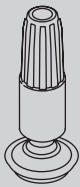

1 7/8-inch-high glide; black nylon stem; steel-plated swivel foot with Floor Saver Glide® insert; for use on hard floors only

Applicable on:

Caper Chairs

Fire Retardancy — Seating

Fire Retardancy

Fire-retardant chairs manufactured in approved fabrics (FR) meet California TB 133 requirements.

All foam and textiles on HermanMiller seating products comply with California TB 117-2013.

State of California
Bureau of Home Furnishings,
Technical Bulletin 133

State of California
Bureau of Home Furnishings,
Technical Bulletin 117-2013

8Z Pellicle		•
AireWeave™ 2		•
Balance		•
Bento		•
Bingo		•
Crepe		•
Crossing		•
Dex		•
Duo		•
Flexnet™	FR	•
Gem		•
Hopsak		•
Intercept		•
InterWeave		•
Latitude™		•
Leather		•
Loom		•
Lyris 2™		•
Marvel		•
Medley		•
Mercer		•
Moiré		•
Monologue		•
Plateau		•
Quilty		•
Rhythm		•
Rivet		•
Sequel		•
Spools		•
Stitches		•
Strata		•
Twist		•
Whisper		•

• Fabric meets California TB 117-2013 code requirements.

FR To meet California TB 133 code requirements, fabrics must be applied to approved chairs identified with FR product numbers.



Proprietary Textiles Application Chart — Seating

• Available

[A] Assigned lead-time textile.

See following page for exception notes.

[N] Non-woven textile.

	Aeron® Chairs	Cosm™ Chairs	Mirra® 2 Chairs/Stools	Celle® Chairs/Stools	Embody® Chairs	Sayl® Work Chairs/Stools	Sayl Side Chairs	Setu® Chairs/Stools	Setu Lounge Chair/Ottoman	Verus™ Work Chairs/Stools Back	Verus Work Chairs/Stools Seat	Verus Side Chairs Back	Verus Side Chairs Seat	Verus Plus Chairs	Aside® Chairs	Caper® Chairs/Stools	Keyn Chair Group Back	Keyn Chair Group Seat	Lino™ Chairs Back	Lino Chairs Seat	Locale® Bench Cushion	Public® Office Landscape Back	Public Office Landscape Seat	Plex™ Lounge Furniture	Swoop™ Lounge Seating - Fully Upholstered	Swoop Lounge Seating - Plywood	Valor™ Seating	Nemschoff® Whisk™ Chairs	Cushion Tops	Workspaces		
Price Category 1																																
COM Customer's Own Material [A]			14		1	1				1	1	1	1	1	1			1		1	1				1	1	1		1	1	1	
231__ 8Z Pellicle®	•																															
1A7__ AireWeave 2			•																													
8T__ Crossing			•					•	•																							
3DE__ Dex			14		•	•				•	•	•	•	•	•			•						•	19	•		•		•		
4RM__ Duo																			•													
6V__ Flexnet™																	•															
95__ Gem			14					•	•														•								•	•
845__ Intercept		•																														
65__ Interweave										•		•																				
4W__ Lyris 2™								•	•																							
1MN__ Monologue			14		24	22		•	•		•	•	•				•	•		•	•		•	•	•	•	•	•	•	•	•	
3DK__ Stretch Knit					21																											
235__ Tailored			•		•	•	•	•	•	•	•	•	•	•	•		•	•		•	•		•	23		•		•		7	•	
1WS__ Whisper			14		24	•	•	•	•	•	•	•	•	•	•		•	•		•	•		•	•	•	•	•	•	•	•	•	
Price Category 2																																
3AR__ Aristo			14		•	•	•	•	•	•	•	•	•	•	•		•	•		•	•		•	•	•	•	•	•	•	•	•	•
92__ Crepe			•		•	•	•	•	•	•	•	•	•	•	•		•	•		•	•		•	•	•	•	•	•	•	•	•	•
3EP__ Epic			14		•	•	•	•	•	•	•	•	•	•	•		•	•		•	•		•	•	•	•	•	•	•	•	•	•
22Q__ Fish Net			•		•	•	•	•	•	•	•	•	•	•	•		•	•		•	•		•	•	•	•	•	•	•	•	•	•
1LM__ Loom			14		•	•				•	•	•	•	•	•		•	•		•	•		•			•	23	•	•	•	•	
1MV__ Marvel [N]						21	22										•															
1HA__ Medley			15		•	•	22			•	•	•	•	•	•		•	•		•	•		•	•	•	•	•	•	•	•	•	•
30__ Rhythm			•	23	•	•				•	•	•	•	•	•		•	•		•	•		•	•	•	•	•	•	•	•	•	•
1RV__ Rivet			14							•	•	•	•	•	•		•	•		•	•		•	•	•	•	•	•	•	•	•	•
3SL__ Sequel [N]			15		•	•	•	•	•	•	•	•	•	•	•		•	•		•	•		•	•	•	•	•	•	•	•	•	•
8R__ Twist			•		•	•	•	•	•	•	•	•	•	•	•		•	•		•	•		•	•	•	•	•	•	•	•	•	•
Price Category 3																																
3AC__ Ace			21		•	•				•	•	•	•	•	•	8		•	•		•	•		•	19		•		•	•	•	
70__ Bento					•	•	•	•		•	•	•	•	•	8		•				•											•
8M__ Latitude™			23		•	•															•				•	•						
22V__ String Plaid			14		•	•				•	•	•	•	•	•		•				•			•			•					
Price Category 4																																
3DM__ Daydream			14		21	•	•	•		•	•	•	•	•	•		•	•		•	•		•	•	•	•	•	•	•	•	•	•
213__ Mercer			14		21	22				•	•	•	•	•	•		•	•		•	•		•	•	•	•	•	•	•	•	•	•
1A9__ Network																																
6S__ Quilty			14		•	•				•	•	•	•	•	•		•	•		•	•		•	•	•	•	•	•	•	•	•	•
22P__ Strata					•	•	•			•	•	•	•	•	•		•	•		•	•		•	•	•	•	•	•	•	•	•	•
3SY__ Sync			•	•	•	•	•	•	•	•	•	•	•	•	•		•	•		•	•		•	•	•	•	•	•	•	•	•	•

Continued on next page

Proprietary Textiles Application Chart — Seating

continued

	Aeron® Chairs	Cosm™ Chairs	Mirra® 2 Chairs/Stools	Celle® Chairs/Stools	Embody® Chairs	Sayl® Work Chairs/Stools	Sayl Side Chairs	Setu® Chairs/Stools	Setu Lounge Chair/Ottoman	Verus™ Work Chairs/Stools Back	Verus Work Chairs/Stools Seat	Verus Side Chairs Back	Verus Side Chairs Seat	Verus Plus Chairs	Aside® Chairs	Caper® Chairs/Stools	Keyn Chair Group Back	Keyn Chair Group Seat	Lino™ Chairs Back	Lino Chairs Seat	Locale® Bench Cushion	Public® Office Landscape Back	Public Office Landscape Seat	Plex™ Lounge Furniture	Swoop™ Lounge Seating - Fully Upholstered	Swoop Lounge Seating - Plywood	Valor™ Seating	Nemschoff® Whisk™ Chairs	Cushion Tops	Workspaces			
Price Category 5																																	
3CY__ Cozy			14		•	•	•	•	•	•	•	•	•	•	•		•	•			•	•		•	•	•	•	•	•	•	•	•	•
14A__ Hopsak			14		•	•	•	•	•	•	•	•	•	•	•		•	•			•	•		•	•	•	•	•	•	•	•	•	•
3SU__ Summit			15		•	•				•	•	•	•								•	•		•	•	•	•	•	•	•	•	•	•
Price Category 6																																	
35__ Balance					•			•																									
Price Category 7																																	
COL Customer's Own Leather [A]	1		14												8																		1
Price Category 8																																	
No fabrics available at this time																																	
Price Category 9																																	
21__ Leather [N]	23		14												8					•							•					•	

All foam and Proprietary Textiles on HermanMiller seating comply with California TB 117-2013.

Application Note: Herman Miller cannot guarantee material/pattern alignment in adjacent products. For example, a fabric's pattern may not align from one pedestal cushion top to the next, or from one chair to the next.

- 1 Refer to price book appendices and Kiosk for COM/COL information.
- 7 Available on 1" Cushion Tops only.
- 8 Only available on non-upholstered outer back (PB) option.
- 9 Available on Valor upholstered seat only.
- 14 Available on Celle UC (upholstered seat) and Celle UF (upholstered seat) Chairs.
- 15 Available only on Celle HC (upholstered seat with protective edge) and Celle HF (upholstered seat) Chairs.
- 19 Available on Plex seat only.
- 21 Not available on Sayl upholstered back work chairs.
- 22 Not available on Sayl side chairs with upholstered backs.
- 23 Available in select colors. Refer to "Proprietary Textile Colors - Seating" for color offering.
- 24 Not available on Sayl upholstered High-Back Work Chairs.

Proprietary Textile Colors — Seating

Price Category 1

Customer's Own Material
See Order Information in
Appendices.
Assigned lead-time textile. A

8Z Pellicle®
For New Aeron® Chairs
56% elastomeric
44% polyester
23101 Mineral
23102 Carbon
23103 Graphite

AireWeave™ 2
For Mirra® 2 Chairs
67% elastomeric
33% antimony-free polyester
1A701 Alpine
1A702 Slate Grey
1A703 Graphite
1A704 Lime Green
1A705 Cappuccino
1A706 Urban Orange
1A707 Dark Turquoise
1A708 Twilight

Crossing
54" wide
86% antimony-free polyester
14% polyester
8T03 Wicker
8T04 Porcelain
8T05 Warm Grey
8T06 Sepia
8T07 Pumpkin
8T08 Copper
8T09 Cranberry
8T10 Tomato
8T11 Mulberry
8T12 Plum
8T13 Green Apple
8T14 Loden
8T15 Spruce
8T16 Periwinkle
8T17 Cerulean
8T18 Indigo
8T19 Shale
8T20 Brownstone
8T21 Bark
8T22 Tin
8T23 Graphite
8T24 Black

Dex
54" wide
50% recycled polyester
50% polyester
3DE01 Frost
3DE02 Silver Pine
3DE03 Stone
3DE04 Shale
3DE05 Charcoal

Duo
For Lino™ Chairs
52% polyester
48% elastomeric
4RM01 Mineral
4RM02 Poppy
4RM03 Green Leaf
4RM04 Jade
4RM05 Shadow
4RM06 Graphite

Flexnet™
For Caper® Chairs
69% elastomeric
31% polyester
6V01 Black
6V02 Silver Grey

Gem
54" wide
100% antimony-free polyester
9502 Tangerine
9503 Red
9507 Twilight
9508 Bayou
9510 Berry Blue
9511 Aqua Green
9512 Green Apple
9514 Black
9515 Slate Grey
9516 Fog

Interweave
For Verus™ Chairs
71% elastomeric
29% polyester
6504 Pewter
6505 Charcoal
6506 Black

Lyris 2™
For Setu® Chairs
74% elastomeric
26% polyester
4W21 Alpine
4W22 Mango
4W23 Chartreuse
4W25 Berry Blue
4W26 Slate Grey
4W28 Chino
4W29 Rattan
4W30 Java
4W31 Graphite

Monologue
54" wide
56% recycled polyester
44% polyester
1MN01 Linen
1MN02 Alabaster
1MN03 Truffle
1MN04 Folkstone
1MN05 Silver Pine
1MN06 Slate
1MN07 Seed
1MN08 Yellow Oxide
1MN09 Persimmon
1MN10 Tundra
1MN11 Meadow
1MN12 Blue Sky
1MN13 Blue Spruce
1MN14 Deep Sea

Stretch Knit
Assigned lead-time textile. A
Available only on Sayl®
Suspension Back Work Chairs
97% polyester, 3% spandex
3DK01 Fog
3DK02 Slate Grey
3DK03 Java
3DK04 Black
3DK05 Red
3DK06 Green Apple
3DK07 Berry Blue

Price category 1 continued on next page

Proprietary Textile Colors — Seating

continued

Price Category 1

continued

Price Category 2

Tailored	
54" wide	
56% polyester	
44% recycled polyester	
23501	Studio White *
23502	Sugar *
23503	Tomato
23504	Orchid
23505	Boysenberry
23506	Chive
23507	Bluegrass
23508	Cobalt
23509	Cadet
23510	Fog
23511	Graphite
23512	Black
23513	Coffee

* Colors not available on Plex™ Lounge Furniture.

Whisper	
54" wide	
73% recycled polyester	
27% polyester	
1WS01	Sand Dollar
1WS02	Pebble
1WS03	Silver Birch
1WS04	Iceberg
1WS05	Silver Pine
1WS06	Carbon
1WS07	Cumin
1WS08	Adobe
1WS09	Strawberry
1WS10	Blush
1WS11	Eggplant
1WS12	Willow
1WS13	Sea Grass
1WS14	Pool
1WS15	Blueberry

Aristo	
54" wide	
88% recycled polyester	
12% polyester	
Acrylic backing	
3AR01	Forest Moss
3AR02	Light Brindle
3AR03	Mink
3AR04	Copper
3AR05	Adobe
3AR06	Cherry
3AR07	Lilac
3AR08	Green Apple
3AR09	Surf
3AR10	Waterfall
3AR11	Cadet
3AR12	Tin
3AR13	Pewter
3AR14	Grey Brindle
3AR15	Grey Black

Crepe	
54" wide	
100% recycled polyester	
9201	Licorice
9203	Smoke
9207	Cherry
9209	Claret
9212	Raisin
9218	Aquamarine
9223	Cadet
9241	Beachglass
9243	Midnight
9244	Artichoke
9248	Warm White
9249	Stone
9250	Earth
9251	Fog
9252	Slate Grey

Crepe continued	
9253	Yellow Dark
9254	Coral
9255	Blush Grey
9256	Wild Berry
9257	Clover
9258	Caribbean
9259	Cerulean
9260	Brownstone
9261	Shale
9262	Graphite
9263	Tomato
9264	Green Apple

Epic	
54" wide	
56% recycled polyester	
44% polyester	
Acrylic backing	
3EP01	Alabaster
3EP02	Smoke
3EP03	Falcon
3EP04	Citrus Spring
3EP05	Copper
3EP06	Urban Orange
3EP07	Poppy
3EP08	Wild Plum
3EP09	Sugar Plum
3EP10	Clover
3EP11	Loden
3EP12	Everglade
3EP13	Mist
3EP14	Peacock
3EP15	Cadet
3EP16	Indigo
3EP17	Spring Wood
3EP18	Grey Brindle
3EP19	Seed
3EP20	Carbon Dark

Fish Net	
55" wide	
100% recycled polyester	
22Q01	Oyster
22Q02	Stone
22Q03	Citrus
22Q04	Curry
22Q05	Chipotle
22Q06	Cherry
22Q07	Fuschia
22Q08	Claret
22Q09	Purple
22Q10	Clover
22Q11	Pesto
22Q12	Peacock
22Q13	Lagoon
22Q14	Twilight
22Q15	Bluestone
22Q16	Storm
22Q17	Black
22Q18	Cocoa

Loom	
54" wide	
100% polyester	
1LM01	Linen *
1LM02	Brown Sugar and Spice
1LM03	Brick and Mortar
1LM04	Salt and Pepper
1LM05	Black
1LM06	Lemongrass
1LM07	Poppy
1LM08	Wild Berry
1LM09	Loden
1LM10	Jade
1LM11	Deep Sea

* Color not available on Valor Seating

Price category 2 continued on next page

Proprietary Textile Colors — Seating

continued

Price Category 2

continued

Marvel	
54" wide	
100% pvc-free polyurethane	
1MV01	Summer White
1MV02	Sand Dollar
1MV03	Espresso
1MV04	Folkstone Grey
1MV05	Graphite
1MV06	Onyx
1MV07	Polar Blue
1MV08	Blush Grey
1MV09	Woodrose
1MV10	Citrus
1MV11	Adobe
1MV12	Red
1MV13	Kiwi Green
1MV14	Pine
1MV15	Teal Green
1MV16	Twilight

Medley	
54" wide	
100% polyester	
1HA01	Stone
1HA02	Trail
1HA03	Charcoal
1HA04	Cinder
1HA05	Citrus
1HA06	Papaya
1HA07	Chutney
1HA08	Tundra
1HA09	Feather Grey
1HA10	Chartreuse
1HA11	Loden
1HA12	Peacock
1HA13	Bayou
1HA14	Blue Grotto
1HA15	Blueberry
1HA22	Khaki
1HA23	Pewter
1HA24	Yellow Oxide
1HA25	Vintage Rose
1HA26	Raspberry
1HA27	Acai Berry

Rhythm	
54" wide	
100% polyester	
3001	Kiwi Green *
3002	Green Apple *
3003	Peacock *
3004	Bayou *
3005	Berry Blue
3006	Iris *
3007	Twilight
3008	Pumpkin *
3009	Poppy *
3010	Molasses *
3011	Mulberry *
3012	Khaki *
3013	Mink *
3014	Black
3015	Charcoal

* Colors not available on Embody Chair

Rivet	
54" wide	
100% recycled polyester	
1RV01	Twig
1RV02	Deep Clay
1RV03	Woodrose
1RV04	Otter
1RV05	Hemlock
1RV06	Olive
1RV07	Lagoon
1RV08	Deep Sea
1RV09	Charcoal
1RV10	Grey Brindle

Sequel	
54" wide	
100% vinyl	
100% polyester knit backing	
Resilience® finish	
3SL01	White
3SL02	Pebble
3SL03	Mushroom
3SL04	Stone
3SL05	Chestnut
3SL06	Rattan
3SL07	Black Cherry

Sequel continued	
3SL08	Tundra
3SL09	Seal
3SL10	Blue Fog
3SL11	Folkstone
3SL12	Shale
3SL13	Slate Grey
3SL14	Charcoal
3SL15	Carbon Dark
3SL28	Navy

Twist	
54" wide	
80% antimony-free polyester	
13% recycled polyester	
7% polyester	
8R05	Wicker
8R10	Poppy
8R14	Tin
8R15	Shale
8R16	Graphite
8R17	Birch
8R18	Sepia
8R22	Blueberry
8R23	Green Apple
8R26	Gunmetal
8R27	Cinder
8R28	Citrus
8R29	Pekoe
8R30	Tangerine
8R31	Red Plum
8R32	Wisteria
8R33	Forest
8R34	Jade Dark
8R35	Waterfall
8R36	Midnight Blue
8R37	Carbon Dark

Price Category 3

Ace	
54" wide	
100% polyurethane	
Polyester knit backing	
Stain resistant finish	
3AC01	Summer White
3AC02	White Ash
3AC03	Rye
3AC04	Metal
3AC05	Clay
3AC06	Chestnut
3AC07	Citrus
3AC08	Camelback
3AC09	Chipotle
3AC10	Claret
3AC11	Slate Purple
3AC12	Artichoke
3AC13	Sepia Dark
3AC14	Aloe
3AC15	Flint
3AC16	Blue Sky
3AC17	Oceanside
3AC18	Midnight
3AC19	Spring Wood
3AC20	Frost
3AC21	Lead
3AC22	Black

Bento	
54" wide	
100% antimony-free polyester	
7001	Frost
7002	Linen
7003	Khaki
7004	Truffle
7005	Grey Black
7006	Pumpkin
7007	Cranberry
7008	Everglade
7009	Cobalt

Price category 3 continued on next page

Proprietary Textile Colors — Seating

continued

Price Category 3

continued

Latitude™

61" wide	
100% polyester	
8M01	Graphite
8M02	Shadow
8M10	Alpine
8M17	Black
8M21	Slate Grey
8M22	Lime Green
8M23	French Press
8M24	Urban Orange
8M25	Dark Turquoise
8M26	Twilight

String Plaid

54" wide	
100% recycled polyester	
22V01	Warm White on Khaki
22V02	Mint on Yellow Green
22V03	Mist on Blue Grey
22V04	Sky Blue on Red
22V05	Lime on Magenta
22V06	Bright Green on Green
22V07	Aqua Blue on Cerulean
22V08	Ivory on Black

Price Category 4

Daydream

54" wide	
48% wool	
41% recycled polyester	
9% nylon	
2% polyester	
3DM01	Rye Grass
3DM02	Silver Birch
3DM03	Pewter
3DM04	Graphite
3DM05	Black
3DM06	Lemongrass
3DM07	Permission
3DM08	Juniper
3DM09	Sea Grass
3DM10	Nightfall

Mercer

54" wide	
50% solution dyed recycled nylon	
50% solution dyed nylon	
BLOCKaide	
21301	Stone
21303	Cayenne
21305	Pesto
21306	Teal Blue
21307	Ultramarine
21310	Charcoal

Network

For Public Office Landscape® sectional back/social chair. knit to size	
100% polyester	
1A901	Warm White
1A902	Fog
1A903	Red
1A904	Wildberry
1A905	Green Apple
1A906	Twilight
1A907	Graphite

Quilty

56" wide	
100% antimony-free polyester	
GreenShield	
6S03	Khaki
6S04	Straw
6S07	Brick
6S10	Mink
6S11	Green Apple
6S13	Indigo
6S14	Zinc
6S15	Slate
6S16	Beachwood
6S17	Paprika
6S18	Plum
6S19	Juniper
6S20	Grey Black

Strata

54" wide	
50% solution dyed recycled nylon	
50% solution dyed nylon	
BLOCKaide	
22P04	Pesto
22P05	Peacock
22P06	Blue Jay
22P07	Blueberry
22P09	Mango
22P10	Paprika
22P12	Wheat
22P13	Brownstone
22P14	Bayou

Sync

55" wide	
100% polyester	
3SY01	Pine Cone
3SY02	Citron
3SY03	Canyon
3SY04	Truffle
3SY05	Wild Berry
3SY06	Everglade
3SY07	Glacier
3SY08	Nightfall
3SY09	Dark Mineral
3SY10	Slate Grey
3SY11	Dark Carbon
3SY12	Black

Price Category 5

Cozy

54" wide	
100% wool	
3CY01	Heathered Warm Grey
3CY02	Heathered Rye Grass
3CY03	Heathered Cool Grey
3CY04	Heathered Blue Grey
3CY05	Heathered Black
3CY06	Heathered Persimmon
3CY07	Heathered Loden
3CY08	Heathered Jade
3CY09	Heathered Lagoon
3CY10	Heathered Twilight

Hopsak

56" wide	
100% recycled polyester	
14A20	Black
14A22	Raw Umber Dark
14A26	Grey Blue Dark
14A30	Sepia Dark
14A38	Emerald Dark
14A39	Yellow Dark
14A40	Orange
14A41	Sienna
14A42	Olive Green Dark
14A43	Crimson
14A44	Crimson Dark Dark
14A45	Violet Dark
14A46	Pink Dark Dark
14A47	Ultramarine Dark
14A48	Cobalt Blue
14A49	Terra Cotta
14A50	Ochre Dark

Summit

54" wide	
100% silicone	
Polyester knit backing	
3SU01	Bright White
3SU02	Oyster
3SU03	Zinc
3SU04	Sparrow
3SU05	Taupe
3SU06	Java
3SU07	Black
3SU08	Cherry
3SU09	Beachglass
3SU10	Midnight

Proprietary Textile Colors — Seating

continued

Price Category 6

Balance

100% polyester

3512 Carbon

3513 Black

Price Category 7

Customer's Own Leather

See Order Information in Appendices. Assigned lead-time textile. A

Price Category 8

No fabrics available at this time.

Price Category 9

Leather

approx. 50 sq. ft. per hide

100% leather

2101 Ivory

2109 Black *

2110 Smoke

2111 Graphite

2112 Khaki

2113 Rattan

2114 Truffle

2115 Alpine

2116 Haze

2117 Sable Grey

2118 Dark Mineral **

2119 Dark Carbon ***

2120 Cranberry

2121 Deep Sea

* Armpad color available on Aeron® Chair, Graphite.

** Armpad color available on Aeron Chair, Mineral.

*** Armpad color available on Aeron Chair, Carbon.

For more information about our products and services or to see a list of dealers, please visit us at HermanMiller.com or call (800) 851 1196.

© 2021 Herman Miller, Inc., Zeeland, Michigan

Distribution Rights

Working together since 1956, Herman Miller and Vitra are the authentic sources of designs by Charles and Ray Eames, Alexander Girard, and George Nelson. All the designs shown in this book are protected by law. Herman Miller has obtained all rights to make and sell these designs. Also, Herman Miller holds exclusive worldwide manufacturing and distribution rights for these products with the following exceptions:

Charles and Ray Eames, George Nelson, and Alexander Girard—Worldwide distribution rights for furniture in all areas except Europe and the Middle East. For those areas, please contact Vitra.

Isamu Noguchi—Worldwide distribution rights for the Noguchi Rudder Table. Distribution rights for the Noguchi Table in North America and Central America only. For all other areas, please contact Vitra.

Magis—Exclusive distribution rights in the US and Canada. For all other areas, please contact Magis.

® **HermanMiller**, , Action Office, Aeron, Aside, Canvas Office Landscape, Caper, Celle, Cosm, Co/Struc, Eames, Embody, Ethospace, Exclave, Fine-Tune, FlexFront, Formcoat, Ground Cloth, Herman Miller Healthcare, Layout Studio, Lino, Maharam, Meridian, Mirra, Motia, Nelson, Pellicle, Perspectives, Plex, PostureFit, PostureFit SL, Resolve, Sayl, Setu, Tu, Verus, Y-Tower, and Z-Axis are among the registered trademarks of Herman Miller, Inc., and its owned subsidiaries.

™ AireWeave, Bubbletack, Cellular Suspension, Commend, Compass, Connect, DOT, Durawrap, Everywhere, Flex-Edge, Headway, Hopsak 2, Intent, Iota, Keyless Entry, Latitude, Lyris 2, Mora, Multiscrim, Nevi, Overlay, Pedastools, Renew, Stackable, Swoop, Thrive, TriFlex, Twist, Valor, and Vista are among the trademarks of Herman Miller, Inc., and its owned subsidiaries.

5Chemsurf® is a registered trademark of Wilsonart International.

Corian® is a registered trademark of E.I. du Pont de Nemours and Company Corporation.

FLEXNET™ is a trademark of Milliken & Company.

Floor Saver Glide® is a registered trademark of Carpin Manufacturing, Inc.

Forest Stewardship Council® is a registered trademark of the Forest Stewardship Council A.C. (FSC). We are FSC® certified (FSC® C102895).

FSC® is a registered trademark of the Forest Stewardship Council A.C. (FSC).

Geiger® is a registered trademark of Geiger International.

MicrobeCare™ is a trademark of Parasol Medical LLC.

Microsoft® and Natural® Keyboard are registered trademarks of Microsoft Corporation.

Place Textiles® is a registered trademark of Place Textiles.